

Instructions



Pulse[®] HUB

3A5414G
EN

For use with Pulse Fluid Management System Components only.

Not approved for use in explosive atmospheres or hazardous locations. For Indoor use only.

Part Numbers:

| Part No. | Approvals |
|----------|-----------|
| 24Z978 | |
| 25D454 | |



Important Safety Instructions

Read all warnings and instructions in this manual and all related Pulse manuals. Save all instructions.

Both devices contain ConnectCore6 i.MX6 WiFi/Bluetooth Radio, IC: 1846A-CCIMX6B.

HUB 24Z978 contains XBee3 Radio, IC: 1846A-XBEE3.

HUB 25D454 contains XBee S2C TH Radio, IC: 1846A-S2CTH.

Both devices contain FCC ID MCQ-CCIMX6B. This device complies with Part 15 of the FCC Rules. Operation is subject to the following two conditions:

- This device may not cause harmful interference.
- This device must accept any interference received, including interference that may cause undesired operation.

HUB 24Z978 contains FCC ID MCQ-XBEE3. This device complies with Part 15 of the FCC Rules. Operation is subject to the following two conditions:

- This device may not cause harmful interference.
- This device must accept any interference received, including interference that may cause undesired operation.

HUB 25D454 contains FCC ID MCQ-S2CTH. This device complies with Part 15 of the FCC Rules. Operation is subject to the following two conditions:

- This device may not cause harmful interference.
- This device must accept any interference received, including interference that may cause undesired operation.

Pulse HUB Overview and Component ID

Pulse HUB Overview and Component ID

The Pulse HUB is a self-contained computer with the Pulse Fluid Management Software preloaded. It also is the Personal Area Network (PAN) host used for RF communication with other Pulse system components (meters, Pump Air Control [PAC's], Tank Level Monitors [TLM's]). Access to the Pulse Fluid Management system is accomplished by http protocol (web browser on the Local Area Network [LAN]).

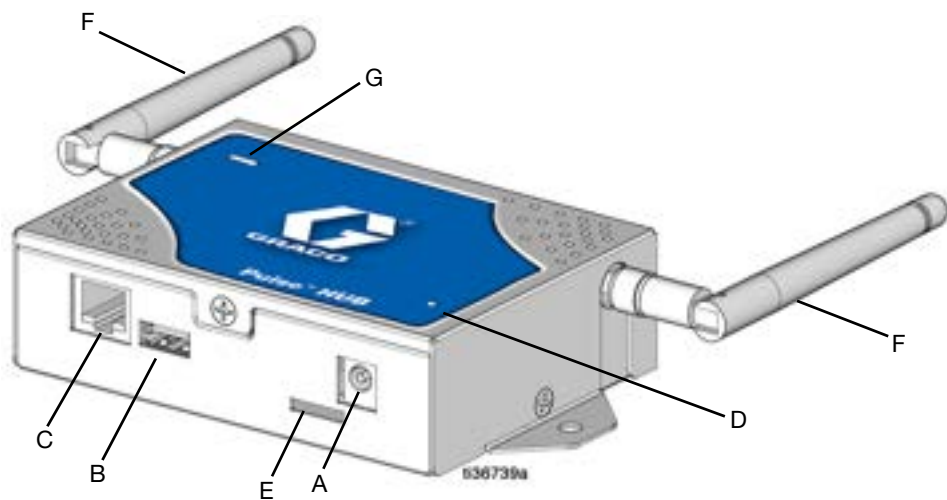

FIG. 1

| Item | Name | Description |
|------|---|--|
| A | Power Inlet Port | Plug end of power adapter into power inlet port (A). The other end of the power adapter is plugged into 120-240 VAC electrical outlet. |
| B | USB Port | USB connection port. |
| C | Ethernet Connection | Supplies connection to the LAN. |
| D | Power Light | Steady, green light. When lit, indicates the unit is receiving power. |
| E | Micro SD Slot | Micro SD card access |
| F | Antenna | External antenna for RF signal transmission |
| G | Pulse Fluid Management Software Status Light | Green, Red, and Orange LED indicated status of the Pulse Fluid Management Software. See HUB Status Light, page 5. |

Installation

Locate the Pulse HUB in the main part of the shop, high on a wall or on the ceiling, in a location that provides an unobstructed line of sight, near the meters, PACs, and/or tank level monitors. Always comply with all applicable local, state and national fire, electrical and safety regulations.

Facility Layout

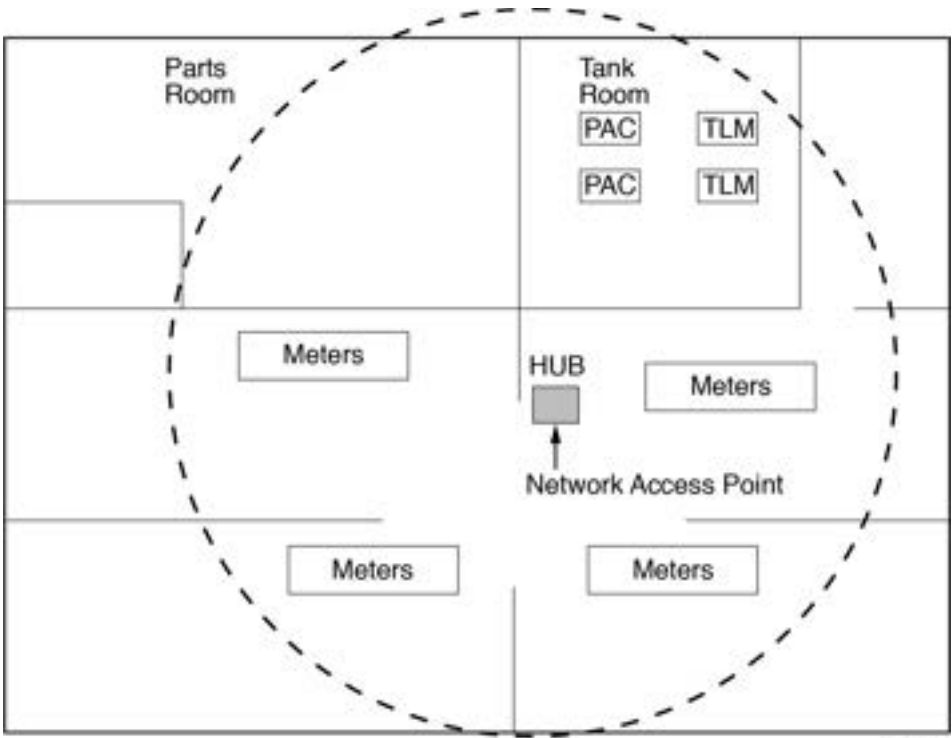

032389a

FIG. 2

Installation

Connecting HUB to LAN (Local Area Network)

There are two options available for connecting the HUB to the LAN: Ethernet Cable (C) or WiFi.



FIG. 3

WiFi Connection

See Setup Your Network Guide included with the HUB for assistance in connection to the LAN network.

HUB Installation

During installation zip-ties or screws can be used to allow relocation of the HUB to optimize RF communication.

Once RF communication is confirmed, the HUB can be permanently mounted on the wall or ceiling.

Secure HUB backplate to wall or ceiling using backplate mounting holes and (user supplied) screws (FIG. 4).

Plug the Pulse Pro Hub into an Uninterruptible Power Supply (UPS) that has surge protection. The minimum specifications are that the power requirements be at least 425 V-A and 260 W with 895 Joules of surge protection. An example is the CyberPower ST425 Standby UPS System.



FIG. 4

Recycling and Disposal

End of Product Life

At the end of the product's useful life, dismantle and recycle it in a responsible manner.

- Remove batteries, circuit boards, LCDs (liquid crystal displays), and other electronic components. Recycle according to applicable regulations.
- Do not dispose of batteries or electronic components with household or commercial waste.



- Deliver remaining product to a recycling facility.

Operation

Once the Pulse HUB is installed, verify that the power light (D) (FIG. 5) is ON and the HUB is functioning correctly.

When the green power light (D) is illuminated it indicates the unit is receiving AC power.

The status of the Pulse Fluid Management Software is indicated by the HUB Status Light (G) (FIG. 5). See HUB Status Lights table below for diagnostic definitions.

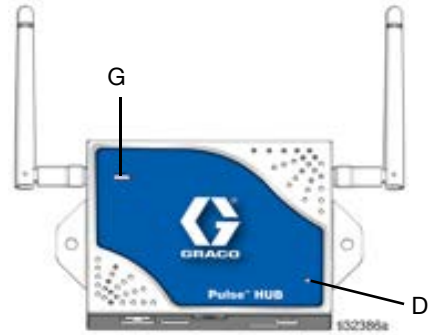

FIG. 5

HUB Diagnostics (D)

| Indicator | Diagnostic Definition |
|-----------------------------|--|
| No green power light | Indicates that AC power is not connected. Verify that the power adapter is securely plugged into the component and the AC power outlet |
| | Verify that the AC power outlet is "live". |

HUB Status Light (G)

| Indicator | Diagnostic Definition |
|--|--|
| Solid Green with Blinking Orange | HUB is running normally using Ethernet. |
| Solid Green with Blinking Red | HUB is running normally using WiFi. |
| Blinking Green with Blinking Orange | HUB is launching or updating using Ethernet. |
| Blinking Green with Blinking Red | HUB is launching or updating using WiFi. |
| Solid Red | HUB has a critical systems failure. |
| Solid Red with Blinking Orange | HUB has a critical systems failure with the Pulse application. |
| Solid Red with Blinking Green | HUB has a critical systems failure with the device network. |

NOTE: On system boot the SBC will cycle through the LED status lights to confirm they are functional.

Software

Software

Main Dashboard

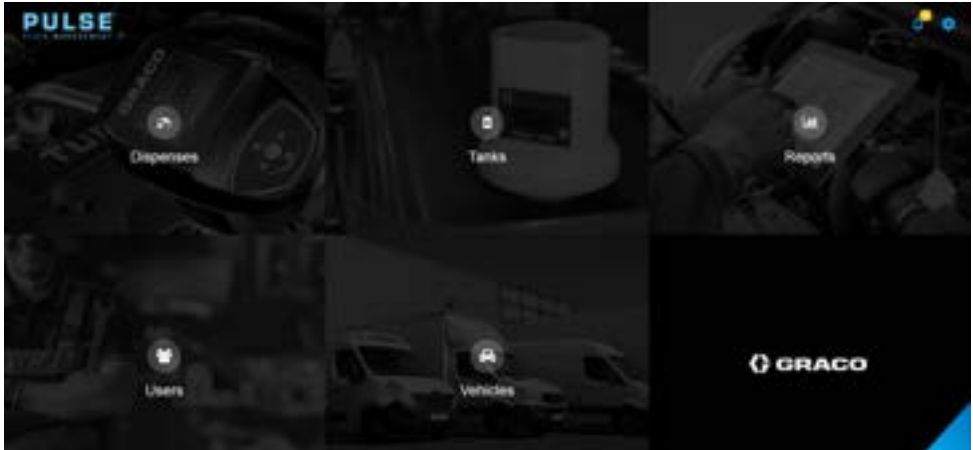

FIG. 6

Dispenses: Based on user's selections, displays as a list of pending, active, completed and canceled dispenses.

Tanks: Displays as a percentage, reports the amount of fluid remaining in the tank. The fluid is measured from the bottom of the tank to the full level.

Reports: The Pulse Fluid Management System generates a variety of reports related to data it collects while the system is operating. Available Reports include:

- Dispense History
- Volumetric History
- Fluid Usage
- Authorization History
- My Reports

Users: There are four User Authorization Levels available in the Pulse Fluid Management System.

- Administrator (system owner or IT professional) - An Administrator has full access to the system. they can perform system updates, change device settings, and add new devices to the system.
- Advanced (parts room/service managers) - An Advanced user can view all system information. They can update virtual tanks and edit and create work orders. They can also authorize dispenses.
- Coordinator (service writers/technicians) - A Coordinator can create and edit work orders.
- Basic (technicians) - A Basic user has the most restricted access to the system. They can log in to the system and interact with the work orders queue.

Vehicles: The Vehicles Group identifies the vehicles in a service fleet.

Software Setup



FIG. 7

Application Settings: General system settings

- General System Settings: Language, Units of Measurement, PIN size, Inactivity Duration
- Time Settings
- Business Schedule
- E-mail Settings
- Network Settings

Device Settings: Device configuration and firmware settings

- Fluids
- Tanks
- Level Monitors
- Pump Control
- Locations
- Meters
- Device Network

Notification Settings: Configures alerts to be displayed on software or e-mail.

- Pump Control
- Meter
- Network Events
- Tank
- Level Monitor

System Setup

Refer to the Setup Your Network, Register Your Devices, and Configure Your Software Settings Quick Start Manuals.

Software

Frequently Asked Questions

- Q.** What does the meter do if the batteries are removed when you are dispensing?

A. If you are not using work orders, the accumulated dispense amount is saved. When fresh batteries are installed, the meter powers up. The next time a dispense ends, two entries are entered in the dispense complete log; the accumulated amount from the first dispense and the dispense just completed.

If the meter is in work order mode, when batteries are reinstalled the meter returns to an end dispense screen, the trigger is disengaged, and the dispensed amount is displayed. The dispense must be ended before another can be started.
- Q.** What does the meter do if a low battery condition occurs during a dispense?

A. The trigger is disengaged and the low battery symbol appears on the meter display. If the meter is allowed to fall asleep in this low battery mode, an attempt will be made to end the dispense. If the attempt is not successful, when fresh batteries are installed, the meter returns to an end dispense screen and an end must occur before another dispense can happen.

If the meter is not using work orders, the accumulated dispense value is saved and entered into the dispense complete log at the next successful end of a dispense.
- Q.** Unplugging the HUB will cause communication over the device to stop immediately. How is this communication reestablished?

A. Make sure the power is disconnect for at least 5 to 10 seconds. Reconnect the power supply and allow 6 to 8 minutes for the system to reboot.
- Q.** Why did my work order disappear from the work order queue?

A. The meter might have received a new profile. After the meter receives a new profile the work order queue is cleaned out.
- Q.** How do I set up a printer?

A. In the Pulse Fluid Management Software, Enable Automatic Print Reports under the General section of Application Settings. Then, open the Pulse Utility Application. On the Settings of the Pulse Utility Application select the printer(s) you would like to send automatic print reports to. Once your printers are selected, navigate back to the home screen of the Pulse Utility Application and click on Start Service. Dispense information will now automatically print to the desired locations.

Troubleshooting

Troubleshooting

| Problem | Cause | Solution |
|---|---|---|
| HUB will not communicate with devices (meters, PAC's, and TLMs) | HUB is not powered up | Verify HUB is powered up |
| | HUB is out of RF range of meters or TLMs | Ensure HUB is located within RF range of meters and TLMs |
| Weak or no RF signal | Changes/obstructions in RF pathway (i.e., vehicles, overhead doors, etc.) | Add Graco Extender to Pulse system. Order Graco Part No. 17F885 - US, 17F776 - EU, 17F887 - UK, 17F888 - ANZ. |

Diagnostic Logs

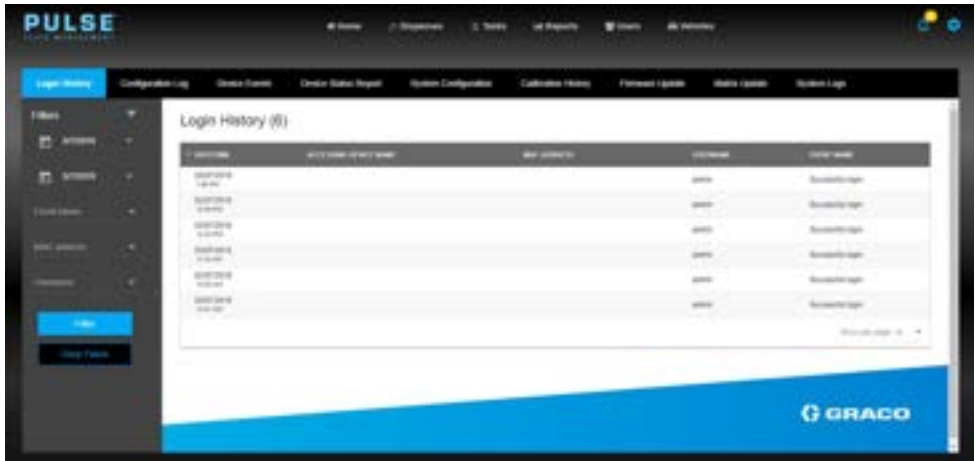

FIG. 8

- Login History
- Configuration Log
- Device Events
- Device Status Report
- System Configuration
- Calibration History
- Firmware Update

Parts

Parts

| Ref | Part No. | Description | Qty |
|-----|----------|------------------------------|-----|
| 1 | 131310 | FLASH DRIVE (not shown) | 1 |
| 2 | 17S458 | ANTENNA | 1 |
| 3 | 17S658 | POWER ADAPTER (not shown) | 1 |
| 4 | | ENCLOSURE | |
| 5 | | LABEL, serial number | 1 |
| 6 | 17E169 | CABLE, Ethernet | 1 |

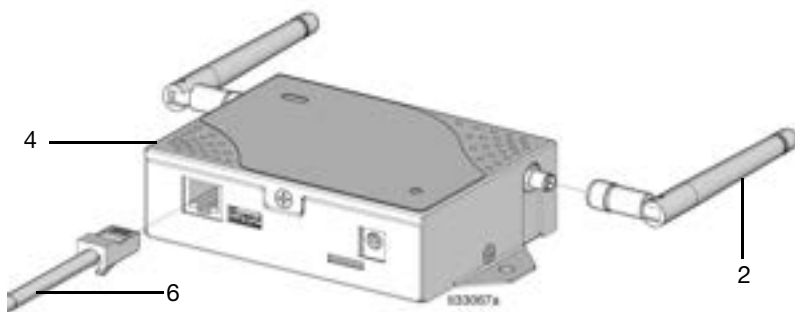

Dimensions

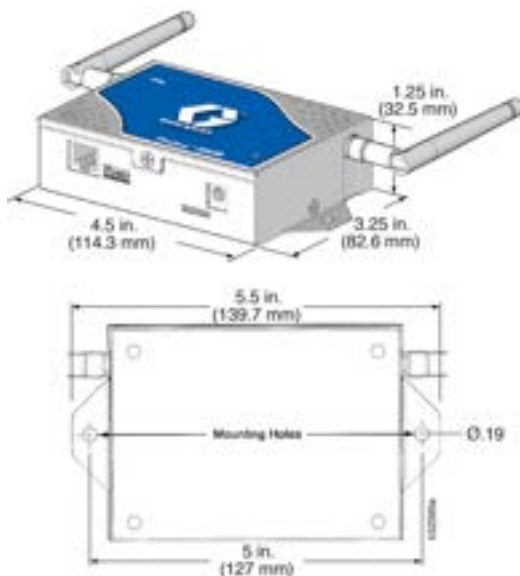

Technical Specifications

Technical Specifications

| Pulse HUB | US | Metric |
|--|--|---------------|
| Weight HUB with Power Adapter | 1.0 lbs | 454 g |
| Operating Temperature Range | -4°F to 122°F | -20°C to 50°C |
| Power Supply | | |
| To Power Supply | 100 - 240 VAC line voltage 50-60 Hz 0.05A | |
| To HUB | 5 Vdc (0.5 amps typ) | |
| RF Frequency Band (PAN) | 2400 - 2483.5 MHz | |
| Maximum RF Transmit Power (PAN) | | |
| Model 24Z978 | 63 mW (18 dBm) | |
| Model 25D454 | 6.3 mW (8 dBm) | |
| PAN Bandwidth | 5 MHz | |
| Radio Modulation | O-QPSK | |
| Maximum WiFi Transmit Power | | |
| Model 24Z978 | 80 mW (19 dBm) | |
| Model 25D454 | 18mW (12 dBm) | |
| WiFi Bandwidth | 20 MHz | |
| Radio Modulation | OFDM, QPSK | |

California Proposition 65

CALIFORNIA RESIDENTS

 **WARNING:** Cancer and reproductive harm – www.P65warnings.ca.gov.

Graco Extended HUB Warranty

Graco warrants all equipment manufactured by Graco and bearing its name to be free from defects in material and workmanship on the date of sale to the original purchaser for use. With the exception of any special, extended, or limited warranty published by Graco, Graco will, for a period of twenty four months from the date of sale, repair or replace any part of the equipment determined by Graco to be defective. This warranty applies only when the equipment is installed, operated and maintained in accordance with Graco's written recommendations.

This warranty does not cover, and Graco shall not be liable for general wear and tear, or any malfunction, damage or wear caused by faulty installation, misapplication, abrasion, corrosion, inadequate or improper maintenance, negligence, accident, tampering, or substitution of non-Graco component parts. Nor shall Graco be liable for malfunction, damage or wear caused by the incompatibility of Graco equipment with structures, accessories, equipment or materials not supplied by Graco, or the improper design, manufacture, installation, operation or maintenance of structures, accessories, equipment or materials not supplied by Graco.

This warranty is conditioned upon the prepaid return of the equipment claimed to be defective to an authorized Graco distributor for verification of the claimed defect. If the claimed defect is verified, Graco will repair or replace free of charge any defective parts. The equipment will be returned to the original purchaser transportation prepaid. If inspection of the equipment does not disclose any defect in material or workmanship, repairs will be made at a reasonable charge, which charges may include the costs of parts, labor, and transportation.

THIS WARRANTY IS EXCLUSIVE, AND IS IN LIEU OF ANY OTHER WARRANTIES, EXPRESS OR IMPLIED, INCLUDING BUT NOT LIMITED TO WARRANTY OF MERCHANTABILITY OR WARRANTY OF FITNESS FOR A PARTICULAR PURPOSE.

Graco's sole obligation and buyer's sole remedy for any breach of warranty shall be as set forth above. The buyer agrees that no other remedy (including, but not limited to, incidental or consequential damages for lost profits, lost sales, injury to person or property, or any other incidental or consequential loss) shall be available. Any action for breach of warranty must be brought within two (2) years of the date of sale Graco makes no warranty, and disclaims all implied warranties of merchantability and fitness for a particular purpose in connection with accessories, equipment, materials or components sold but not manufactured by Graco. These items sold, but not manufactured by Graco (such as electric motors, switches, hose, etc.), are subject to the warranty, if any, of their manufacturer. Graco will provide purchaser with reasonable assistance in making any claim for breach of these warranties.

In no event will Graco be liable for indirect, incidental, special or consequential damages resulting from Graco supplying equipment hereunder, or the furnishing, performance, or use of any products or other goods sold hereto, whether due to a breach of contract, breach of warranty, the negligence of Graco, or otherwise.

FOR GRACO CANADA CUSTOMERS

The parties acknowledge that they have required that the present document, as well as all documents, notices and legal proceedings entered into, given or instituted pursuant hereto or relating directly or indirectly hereto, be drawn up in English. Les parties reconnaissent avoir convenu que la rédaction du présente document sera en Anglais, ainsi que tous documents, avis et procédures judiciaires exécutés, donnés ou intentés à la suite de ou en rapport, directement ou indirectement, avec les procédures concernées.

Graco Information

For the latest information about Graco products, visit www.graco.com.

For patent information, see www.graco.com/patents.

TO PLACE AN ORDER, contact your Graco distributor or call to identify the nearest distributor.
Phone: 612-623-6928 or **Toll Free:** 1-800-533-9655, **Fax:** 612-378-3590

All written and visual data contained in this document reflects the latest product information available at the time of publication.

Graco reserves the right to make changes at any time without notice.

Original instructions. This manual contains English. MM3A5414

Graco Headquarters: Minneapolis
International Offices: Belgium, China, Japan, Korea

GRACO INC. AND SUBSIDIARIES • P.O. BOX 1441 • MINNEAPOLIS MN 55440-1441 • USA

Copyright 2018, Graco Inc. All Graco manufacturing locations are registered to ISO 9001.

www.graco.com

Revision G, May 2024